

Speaking their language: The role of cultural content integration and heritage language for academic achievement among Latino children

J. Sharif Matthews^{a,*}, Francesca López^b

^a Montclair State University, 1 Normal Avenue, Montclair, NJ 07043, United States

^b University of Arizona, 1430 E Second Street, Tucson, AZ 85721, United States

ARTICLE INFO

Keywords:

Asset-based instruction
Bilingual education
Spanish language
Teacher beliefs

ABSTRACT

Asset-based pedagogy (ABP) reflects teacher instructional choices that affirm students' ethnicity and culture in the classroom and curriculum. The current study examines two key enactments of ABPs for Latino children, namely *cultural content integration* and *heritage language* (Spanish). Utilizing an explanatory sequential mixed methods design, we assess mediation and moderation effects between teacher beliefs ($n = 33$), their ABPs, and the mathematics achievement of 568 Latino children in grades three through five. Next, we use qualitative interviews to probe teachers' understanding and value of cultural content integration, heritage language, and how these work together in their own instructional practice. The quantitative results reveal that honoring students' heritage language (Spanish) is the mediating element through which cultural content integration predicts mathematics achievement for Latino children. Further, the moderated mediation analysis, cross-validated by the teacher interviews, showed evidence that high teacher expectations alone may not be enough to predict teacher enactment of ABPs. Instead, critical awareness along with high expectations work together to predict enactment of culturally responsive teaching and growth in Latino students' learning. Implications and limitations are discussed.

"Uh, I don't speak Spanish very well. The little bit of Spanish I do speak I picked up here. I find one of the things that I can do in that light that students respond to is I could have them teach me, which they get into, and then let them make fun of me when I mispronounce things. They love that! Um, but it-it definitely has value." – Ms. Gomar (Latina, teaching 13 years)

Scholars have established that there are unique competencies that are essential to the effective teaching of minoritized youth who face onerous obstacles associated with prejudice, oppression, and poverty (Gay, 2010; González, Moll, & Amanti, 2005; Ladson-Billings, 1999). Collectively, these competencies include teacher knowledge and behaviors that affirm students' ethnicity and culture, challenging instructional approaches that assume deficiencies in the child or the child's culture. In the opening quote, one teacher from our sample demonstrates that she does not perceive students' heritage language as a deficiency nor as a barrier to academic learning. In fact, she utilizes her own weaknesses in Spanish as an opportunity to empower students by reinforcing their knowledge-base and ultimately creating opportunities for belonging as well as learning.

Known by various terms, *asset-based pedagogy* (ABP) suggests that teachers who understand the sociohistorical influences on marginalized

students' educational trajectories are better able to incorporate practices that validate students' culture into their instruction (see López, 2016). In the current study, we examine two key enactments of ABPs for Latino children: *cultural content integration* and honoring *heritage language* (i.e., Spanish). Further, we examine two teacher beliefs, *expectations* and *critical awareness*, as potential antecedents of ABPs and whether ABPs in turn predict Latino students' mathematics achievement in grades three through five. To address these questions, we use an explanatory sequential mixed methods design (Creswell, 2003) to assess mediation and moderation effects between teacher beliefs, their asset-based pedagogies, and student mathematics achievement, measured via teacher surveys and student standardized mathematics achievement scores. Next, utilizing qualitative interviews, we probe teachers' understanding and value of cultural content integration, heritage language, and how these work together in their own instructional practice.

We use standardized mathematics achievement as an important outcome for this study to highlight the power of culture and language beyond their obvious connections to literacy achievement. While some may perceive mathematics to be culture-free and objective by nature, research is beginning to show the roles culture, context, and language

* Corresponding author.

E-mail addresses: Matthewsj@montclair.edu (J. Sharif Matthews), falopez@email.arizona.edu (F. López).

play for student performance in mathematics (Clarkson, 2007; Gutiérrez, 2002; Gutstein, 2008). This study extends this line of work to illustrate the far-reaching effects of culture in learning and the need for ABPs even in domains that are perceived to be objective and non-partisan (e.g., mathematics).

1. Review of the literature

1.1. Asset-based pedagogies

Many efforts to address achievement disparities for poor children of color have been rooted in deficit orientations that reflect the superiority and validity of white middle-class practices, expectations, and experiences (see Banks, 1993; Gutierrez & Rogoff, 2003; Tharp, 1989; Valenzuela, 1999). This perspective emerged prominently during education reforms in Lyndon B. Johnson's *War on Poverty* initiative, which provided the first special funding in U.S. history for compensatory programs (Title I) for children living in poverty. Despite the altruistic intentions of this initiative, this reform effort also fostered the notion of a "culture of poverty" (Kantor, 1991, p. 65) believed to be inherent among poor youth. The belief reflected in these compensatory programs was: "If the environment failed to equip poor children with the cultural resources needed for success at school... the school had to compensate poor children for the disadvantages of being born poor by changing their culture" (Kantor, 1991, p. 66). Thus, a deficit frame began to permeate educational initiatives for poor children, particularly children of color.

Classroom approaches that rejected deficit orientations have evolved to reflect asset-based approaches, which we collectively refer to as asset-based pedagogies (ABPs). These approaches view students' differences as potential assets, contesting the ways differences are too often reduced to deficiencies. Some of the most widely cited ABP orientations include culturally relevant pedagogy (Ladson-Billings, 1995a, 1995b), culturally responsive teaching (Gay, 2010), and Funds of Knowledge (González et al., 2005), but there are numerous additional conceptualizations (see López, 2017). However, Gay (2010) asserts, "Although known by many different names...the ideas about why it is important to make classroom instruction more consistent with the cultural orientations of ethnically diverse students, and how this can be done, are virtually identical" (p. 31). Two key factors reflected in the ABP literature that we examine in the current study are (1) cultural content integration and (2) heritage language (Spanish in this study) as integral pedagogical practices for historically marginalized Latino students.

Cultural Content Integration. Cultural content integration (CCI) concerns teachers' provision and integration of their students' culture into instruction—particularly culture that is not typically validated in the formal curriculum. The emergence of CCI is a response to over a century of U.S. discriminatory practices that have led to an unrelenting undermining of Latino¹ children's culture and language in educational institutions. In the present study, the presence of Mexican-descent Latino children is predominant.

In 1848, the Treaty of Guadalupe Hidalgo ended the Mexican American War and transferred 530,000 miles of once-Mexican territory to the United States, including present-day Arizona, California, western Colorado, Nevada, New Mexico, Texas, and Utah. Simultaneously, this initiated the beginning of decades of persistent prejudice against people of Mexican descent in these regions of the newly-expanded United States (San Miguel & Valencia, 1998). By the 1870s, Spanish language was prohibited in public schools, and officials began to purge Mexican culture from the curriculum. In its place, an Anglo-centric curriculum

was disseminated through historical textbooks, which contained mostly denigrating perspectives about Mexicans and their presence in the United States (San Miguel & Valencia, 1998). Thus, a deficiency-orientation toward Mexican-descent children has been a historical marker of their educational experiences, particularly within the Southwest United States. Unfortunately, these issues and perspectives continue to persist into the present (Gándara & Orfield, 2012).

To counter the development of inequitable and hegemonic curricula, the ABP literature encourages teachers incorporate students' culture into the curriculum to affirm "the legitimacy of cultural heritages of different ethnic groups, both as legacies that affect students' dispositions, attitudes, and approaches to learning and as worthy content to be taught in the formal curriculum" (Gay, 2010, p. 29). Although cultural content integration "is probably the most widely implemented but least studied aspect of multicultural education" (Zirkel, 2008, p. 1150), some evidence exists on its role in improving student learning and interethnic relations (for a review, see Zirkel, 2008). More recent attempts to document the role of CCI have produced research that examines the relation between ethnic studies curricula and improved academic outcomes for historically marginalized students (e.g., Cabrera, Milem, Jacquette, & Marx, 2014; Dee & Penner, 2016). Further, research in mathematics education specifically has shown how creating a mathematics curriculum based upon the lived cultural experiences of Latino students was integral in helping students develop a critical sociopolitical consciousness of their world en route to also developing their mathematical proficiency (Gutstein, 2008). Altogether, this burgeoning body of research suggests integrating cultural content into instruction is not only valuable for building community and social awareness, but is also related to academic achievement and learning. We further investigate these claims in the present study.

Heritage Language (Spanish). Honoring student language is a key consideration in ABP, as language plays an integral role in the development of culture and identity. González (2001) illustrates this in her examination of the identities of Latino children and their mothers in her seminal book, *I Am My Language*. Here González explains, "Language is at the heart, literally and metaphorically, of who we are, how we present ourselves, and how others see us" (p. xix). This view is shared by others, including Darder (2012) who asserts, "It is critical that educators recognize the role language plays as one of the most powerful transmitters of culture, and as such, its central role to both intellectual formation and the survival of subordinate cultural populations" (p. 36). It is this idea of language as a 'powerful transmitter of culture' that we attend to in the current study. Moreover, we view the matter of examining language and its role in achievement trajectories as one that applies not only to students for whom English is a second language, but also for Latino youth that have been prevented from maintaining their Spanish due to restrictive policies (see García, 2009), such as Arizona's A.R.S. § 15-752, which repealed bilingual education and replaced it with Structured English Immersion. This suggests that to effectively integrate Latino students' culture into instruction, teachers must honor students' Spanish language in doing so. Integrating culture without honoring heritage language would likely be superficial and disingenuous, potentially affecting students' engagement in an environment where they do not feel seen, acknowledged, or known (Gutstein, 2008; Kohl, 1991). However, there is little empirical data to support this notion that language is the medium through which cultural content can be effectively integrated into instruction for academic learning.

Some elementary teachers may recognize the value of students' heritage language during literacy instruction. However, when it comes to mathematics instruction, teachers often assume the heritage language of an English learner is irrelevant at best and prohibitive at worst for mathematics learning in an English-based classroom. There is noteworthy research, however, to contradict this popular belief. Clarkson (2007) demonstrates that bilingualism can be a cognitive resource aiding metacognition, and that early elementary bilingual students who succeed in mathematics often make use of their two languages when

¹ We use the term Latino to reflect, collectively, the variability in Latino students' backgrounds that include South America, Mexico, as well as Indigenous backgrounds. The students in the present study, however, are overwhelmingly identified as having Mexican descent.

engaging in mathematical reasoning. Further, ample bilingualism research (Baker, 1996; Clarkson, 1992, 2007; Secada, 1992) suggests that if both languages (a) have enough social value to flourish as languages of thought and expression and (b) meet the minimum threshold of competence, fully bilingual students have greater mathematics achievement and problem solving outcomes compared to their monolingual peers or bilingual peers dominant in only one language.

Altogether, this previous work suggests that the more social value elementary school teachers give to Latino students' Spanish language and the more teachers utilize Spanish in combination with English to promote mathematical reasoning, the greater the likelihood of increased mathematical competencies and achievement for elementary students. While some research provides an understanding of the role of Spanish language in promoting reading achievement among ethnic minority children (e.g., López, 2017), there is little in this regard for mathematics achievement (see Turner & Drake, 2016). In the current study, we test whether elementary teachers' use of Spanish predicts year-end mathematics achievement. Such a finding would demonstrate that the value of honoring heritage language extends beyond literacy achievement and can include mathematics achievement as well, where the importance of multiple language connections for mathematical reasoning is sometimes underestimated.

1.2. Predictors of asset-based pedagogies

Beyond a rote understanding of the importance of CCI and Spanish language, what teacher dispositions and mindsets are necessary for consistent and high-level engagement in these ABPs? Two perspectives suggested by theory and previous research are teacher *expectations* of their students and a *critical awareness* of the structural and systemic barriers many poor children and children of color face (Darder, 2012; McKown, 2013; Tenenbaum & Ruck, 2007).

Teacher Expectations. The accumulation of evidence on the potentially deleterious ways in which teacher expectations can influence students' outcomes is often traced back to Merton's (1948) self-fulfilling prophecy: "a false definition of the situation evoking a new behavior which makes the originally false conception come true" (p. 195). What began with the observation of the potential contamination of interpersonal expectations in a psychology experiment, evolved to *Pygmalion Effects in the Classroom* (Rosenthal, 1994). In their pivotal study, Rosenthal and Jacobson (1968) found that the children in an experimental group, whose teachers had been led to believe they would demonstrate greater gains at the end of the school year, indeed had greater achievement gains versus the control group children. Although their study was criticized for methodological flaws (see Brophy & Good, 1970; Jussim & Harber, 2005, p. 365), a generation of teacher expectations research ensued.

While distinguishing knowledge from belief is difficult in research (Pajares, 1992), teacher expectations have been defined as "inferences (based on prior experiences or information) about the level of student performance that is likely to occur in the future" (Good & Nichols, 2001, p. 113). In their review of decades of research on teacher expectation effects, Jussim and Harber (2005) concluded, "Students who belong to a stigmatized group may be particularly vulnerable to self-fulfilling prophecies" (p. 143). In their review, however, only two studies that focused exclusively on teacher expectations had examined teacher expectation effects among stigmatized students, of which only one examined the role of race/ethnicity and social class; Jussim, Eccles, and Madon (1996) found teacher expectation effects for stigmatized groups were considered "large by any standard" (p. 143). Despite this finding, the researchers asserted that because stigmatized students' performance was consistent with teacher beliefs, the expectations were ultimately accurate². Jussim and Harber's (2005) review

notwithstanding, however, scholars have established that teachers' expectations are indeed often biased against students' cultural backgrounds (McKown & Weinstein, 2002; Tenenbaum & Ruck, 2007). Consequently, it is insufficient to merely examine whether teachers' expectations of students' performance are aligned with students' performance; researchers must also consider the extent to which teachers' expectations reflect bias.

In this study, we argue that teacher critical awareness, also often referred to as *equity literacy* (Gorski, 2013) or *critical consciousness* (Valenzuela, 2016), may be one such factor to elucidate teacher bias implicit within their expectations for their students. In education research and practice, there has been much discourse about the importance of teachers maintaining high expectations for their students, specifically for historically marginalized students (Rosenthal, 1994; Spiegel, 2012; Zhang, 2014). However, we propose that 'high expectations,' although requisite, are not enough alone and remain an inert ingredient to ABPs if they are not combined with critical awareness.

Teacher Critical Awareness. Critical awareness is viewed as knowledge that mitigates bias and prejudice by understanding (a) the historical context of marginalized students; (b) the discrepancy between what is typically validated as knowledge in classrooms and the challenges to those assumptions; and (c) the ways in which curricula in schools serve to replicate the power structure in society (e.g., Apple, 2004; Bowles & Gintis, 1976; Darder, 2012; Freire, 1970; Ladson-Billings, 2003). Accordingly, critical awareness is considered essential knowledge that enables teachers to engage in quality teaching with historically marginalized students (Banks, 1993; Darder, 2012; Gay, 2010; Gorski, 2013; Ladson-Billings, 1995a). That is, critical awareness allows us to consider how to ameliorate the ways in which teachers' expectations can reflect biases against students' cultural backgrounds (e.g., McKown & Weinstein, 2002; Tenenbaum & Ruck, 2007). Researchers have documented that coursework for teachers designed to increase critical awareness has been shown to reduce biased beliefs (Kumar & Hamer, 2013).

Theoretical Foundation. Beyond the empirical work described above, Social Equity Theory (SET; see McKown, 2013) offers an explanation of two social processes that interconnect teacher beliefs, practices, and student outcomes. McKown (2013) refers to *direct influences* as factors that are not contingent on ethnicity and include "the quality of instruction and the quality of student-teacher relationships" (p. 1123). In the research literature, we have a firm understanding of the role of these classroom factors on students' achievement, and this body of work details the link between teachers' expectations, how they deliver instruction, and in turn, how these behaviors are associated with students' mathematics achievement (Brophy & Good, 1984; NCTM, 2014; Tate, 2005).

SET also asserts, however, that by the time children reach about eight years of age, direct influences fail to fully explain student achievement disparities. Importantly, at that age, most marginalized students are developmentally capable of perceiving "social events that signal to members of negatively stereotyped groups that they are devalued because of their group membership" (McKown, 2013, p. 1125), known as *signal influences*, which contribute differentially to their achievement disparities. Thus, in contrast to direct influences, signal influences are viewed as being contingent on race/ethnicity. Accordingly, signal influences can be transmitted through group composition, as well as curricular materials and teacher behaviors. Moreover, because teacher expectations are often informed by their perceptions of students' cultural backgrounds (McKown & Weinstein, 2002;

(footnote continued)

fulfilling prophecy" that influences students' outcomes on pp. 288–289. That said, the researchers also attend to detailing the limitations introduced by omitted variables—and this is consistent with our argument that critical awareness is one such variable that merits exploration.

² Jussim et al. (1996) describe research that suggests that it is "accuracy more than self-

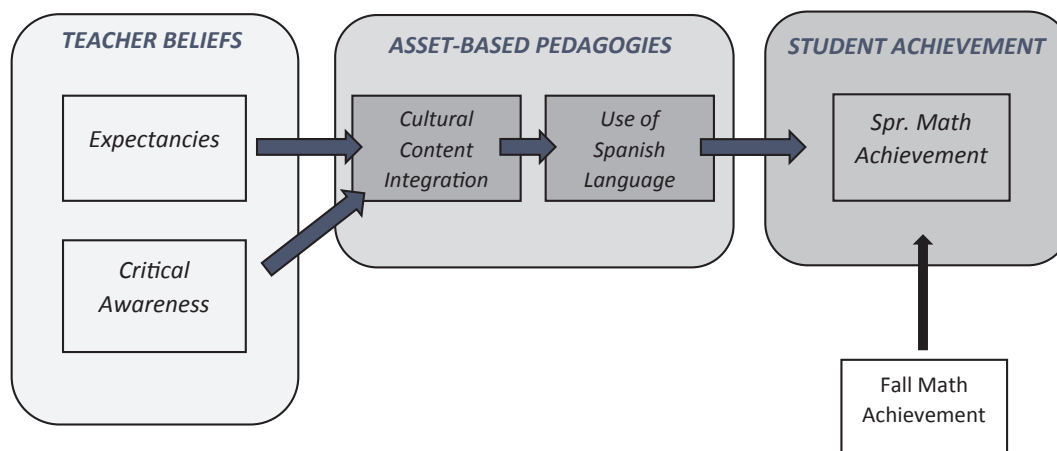

Fig. 1. Conceptual model.

Tenenbaum & Ruck, 2007), they also can produce signal influences.

To abate biased teacher expectations that result in signal influences, scholars assert that another malleable factor, critical awareness, is essential (e.g., Banks, 1993; Darder, 2012; Freire, 1970; Ladson-Billings, 2003). Teachers with critical awareness are believed to engage in fewer deleterious behaviors not only due to lower levels of bias, but also because of their engagement in ABPs, which signals to members of negatively stereotyped groups that their culture is acknowledged and respected (e.g., Darder, 2012; Gay, 2010; Ladson-Billings, 1995a). As such, scholars assert ABP is essential to counter mainstream teaching practices that transmit social messages about the numerous ways historically marginalized students' cultural backgrounds are incompatible with the majority culture reflected in schools.

2. Research questions

Altogether, the current study links teacher beliefs (*expectations* and *critical awareness*) to teacher-reported ABP behaviors (*cultural content integration* and *Spanish language*) to predict mathematics achievement for Latino students in grades 3–5 (see Fig. 1). An explanatory sequential mixed methods design (Creswell, 2003) was employed to assess mediation and moderation effects between the proposed variables (measured via surveys and student achievement scores) as well as probe teachers' understanding of these issues and how they work together in their own practice (assessed via structured interviews with teachers). Specifically, we pose the following research questions.

Research Question 1: Do asset-based pedagogies mediate the relation between teacher beliefs and student mathematics achievement? Specifically, using survey data, we examine whether teachers' CCI into everyday instruction mediates the association between teachers' expectations of their students, critical awareness of the challenges Latino students face in education, and their students' mathematics achievement (Mediation Model 1a). Second, we examine whether teachers' use of Spanish language during instruction mediates the relation between their CCI and student growth in mathematics achievement (Mediation Model 1b). Altogether we propose teachers' CCI and use of Spanish language in instruction as consecutive (serial) mediators between teacher beliefs and student mathematics achievement. Research (Baker, 1996; Clarkson, 2007; Secada, 1992) as well as theory (Darder, 2012; González, 2001) suggests that honoring student language is an essential aspect of integrating cultural content into instruction. Thus, CCI and Spanish language likely work together in translating teacher beliefs into asset-based instruction; although the implications of these for student academic outcomes, specifically mathematics achievement, has not been well tested.

Research Question 2: Building upon the first research question, our second question assesses whether the mediational pathway of teacher

ABPs (i.e., CCI and use of Spanish language) between teacher expectations and student mathematics achievement is moderated by teacher critical awareness. Through this moderated mediation analysis, we expect the interaction of teacher expectations and critical awareness will be an important predictor of CCI beyond their individual contributions and will in turn predict use of Spanish language and student mathematics achievement over the year. Such a finding would underscore that while teacher expectations can be biased against students' cultural backgrounds, critical awareness can potentially mitigate that bias and allow for adopting ABPs in hopes of affirming students' culture and counteracting the various challenges Latino children face in the U.S. educational system.

Research Question 3 Our last question examines how teachers conceptualize and discuss the importance of CCI and Spanish language in their classrooms. Specifically, for teachers of Latino children who show high expectations and critical awareness, how do they negotiate the challenges of integrating students' culture and language in the classroom? Further, what do they perceive are the benefits of these asset-based pedagogies?

3. Methods

3.1. Design

This study used an explanatory sequential mixed method design. A mixed methods research design is a procedure for collecting and analyzing data produced through multiple methods, usually both quantitative and qualitative methods, where data is "mixed" or integrated at some stage of the research process for the purpose of gaining a better understanding of the research problem (Creswell, 2005). Explanatory sequential mixed methods designs usually consist of two distinct phases. The researcher first collects and analyzes quantitative data, which is followed by a qualitative data collection and analysis phase to help refine, explain, build on, or elaborate the initial quantitative results (Creswell, Plano Clark, Gutman, & Hanson, 2003).

The quantitative phase of the current study examined whether teachers' expectations and critical awareness of their Latino students predicted their ABPs and students' subsequent mathematics achievement. Given the robust sample size of the quantitative data along with its purpose for establishing the predictive qualities of teacher beliefs and ABPs, it was given priority in this study's design (Creswell, 2003). The qualitative phase of this study sought to elaborate on the quantitative findings with interviews of select teachers who had the highest scores on teacher expectations and critical awareness; to discuss how they enacted ABPs in their classrooms. Integration (Ivankova, Creswell, & Stick, 2006) occurred at three points during the study: first, during the development of the qualitative interview protocol based on the

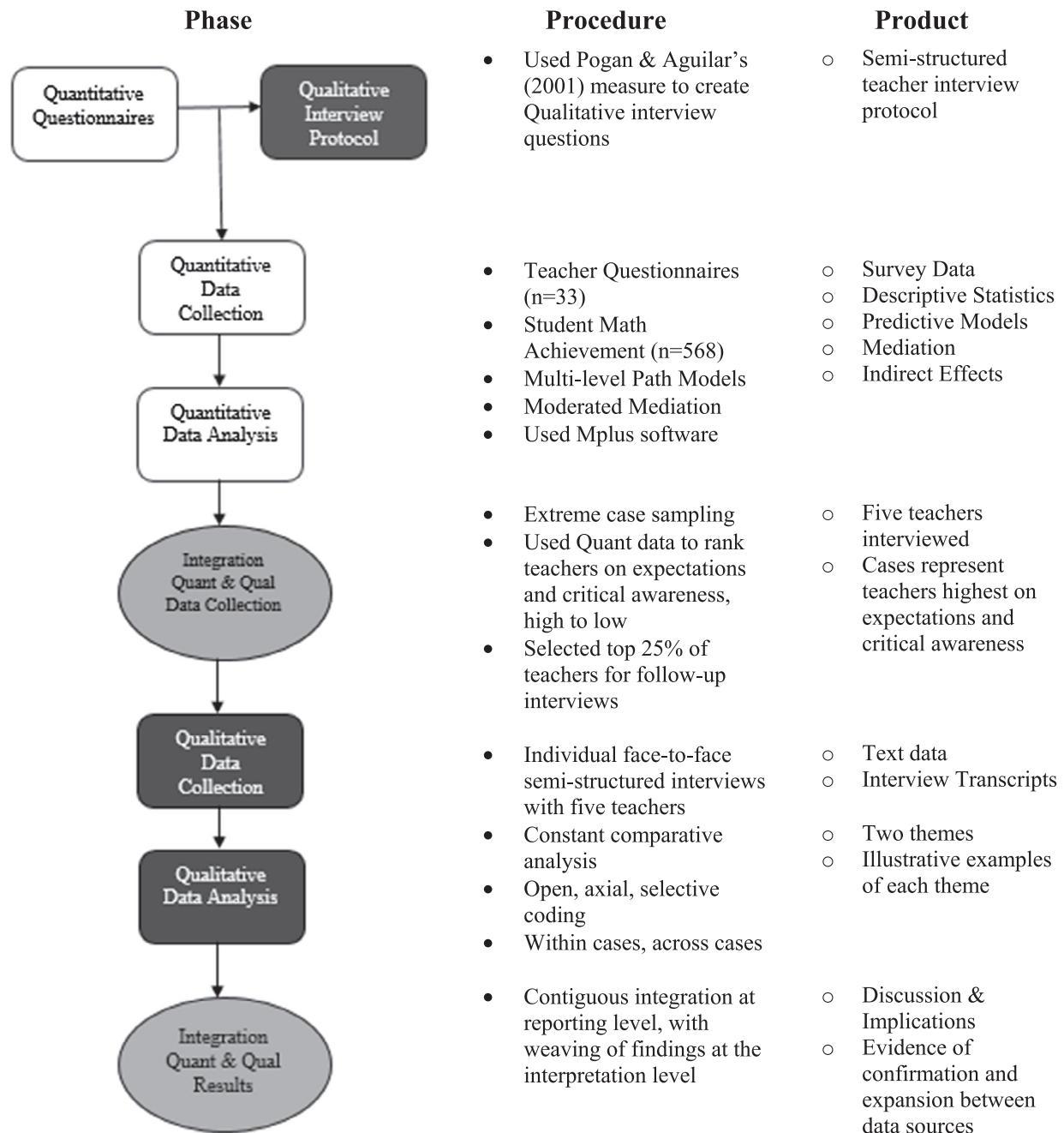

Fig. 2. Diagram of study design and mixed methods integration.

quantitative survey items; second, during the selection of teachers for interviews; and third, during the interpretation phase of the findings (see Fig. 2). This mixed methods research was guided by a pragmatic perspective (Shannon-Baker, 2016), which underscores that knowledge can be both contextualized and generalizable, allowing for both subjectivity and objectivity (i.e., inter-subjectivity) in our collection, analysis, and interpretation of the data.

3.2. Setting and sample

After the school district Institutional Review Board granted permission to conduct the study during the 2013–2014 and 2014–2015 school years, thirteen schools located in an urban district in southern Arizona that was approximately 65% Latino were identified for recruitment in consultation with school district personnel. Approximately 46% of the Latino student population in the district qualified for free or

reduced lunch, and close to 5% of Latino students were classified as English learners.

The participating schools for the proposed project were selected because of their predominantly Latino student populations and their disparate curricular approaches, as well as absence of disparities in academic achievement (i.e., none of the participating schools had been considered by the district as schools in need of remediation). Namely, schools fell along a continuum with some explicitly valuing students’ culture and language (e.g., an emphasis on bilingualism, cultural extracurricular activities, and/or explicit focus on multicultural education and social justice), whereas others had no mention of social justice, ABPs, or other expressions of valuing diversity among students. This range of schools was identified with assistance from participating school district personnel who supervised culturally responsive programming. The principals of these schools were informed of the study and subsequently contacted via telephone and email to request a

meeting. Twelve principals granted site authorization to recruit teachers and students. Teachers in grades three to five (N = 119) in the twelve schools were informed of the study. Thirty-three teachers across seven schools gave voluntary, informed consent. In participating classrooms, approximately 1250 students were asked to provide parents/guardians with informed consent forms and return them; 45% of the students returned the forms indicating their guardian’s permission to disclose achievement scores (n = 568). Approximately 10% of the participating students were classified as English learners.

Procedure. Teachers were provided with hard copies of surveys during the early fall of each school year. They were directed to fill them out at their convenience over a period of four weeks. They also provided information on their training background, years taught, and certification. After the thirty-three teachers completed the questionnaires, basic descriptive statistics were run on the entire sample. Specifically, we computed the mean on the key independent variables: teacher expectations and critical awareness. Teachers were then ranked from high to low, according to their composite scores on these two measures. Based on that ranking, we targeted the teachers within the top 25% of scores (i.e., eight teachers) for follow-up semi-structured interviews. Of those teachers targeted, five agreed to follow-up interviews. Using extreme case sampling to select teachers with exceptionally high scores allowed for an in-depth perspective of the teacher beliefs and behaviors and for a powerful and exemplary enactment of asset-based instructional practices.

Mathematics achievement. The participating school district used standardized formative mathematics assessments that were aligned with the state’s academic standards. All assessments were created to reflect the state standards-aligned content students were expected to know by March. The assessment results included students’ achievement in terms of raw items and percentage correct (out of 50 across all grade levels); the items were generated based on the difficulty and discrimination parameters that reflect parallel assessments across administrations within each grade level (Bergan, Burnham, Bergan, & Bergan, 2011, p. 21). The marginal reliabilities ranged from 0.70 to 0.95. The assessment was administered four times throughout the school year between September and May. The first benchmark scores in September were used as a control for prior mathematics achievement.

Teacher beliefs - Critical awareness and expectations. Items for the teacher beliefs questionnaire included modified items from Pohan and Aguilar’s (2001) *Professional Beliefs about Diversity* scale, as well as items developed specifically for the study, categorized to assess teachers’ beliefs reflecting critical awareness and expectations. Teachers were asked to self-report the extent to which they agreed (1 = strongly agree, 5 = strongly disagree) with five statements reflecting critical awareness (e.g., Tests, particularly standardized tests, have frequently been used as a basis for segregating Latino students). This scale showed an internal consistency of $\alpha = 0.75$ and showed acceptable fit in a confirmatory factor analysis, $\chi^2 = 20.80$, $df = 4$, $p < .001$, CFI = 0.98, TLI = 0.95, SRMR = 0.02, RMSEA = 0.08 [90% CI 0.05, 0.11] (Hooper, Coughlan, & Mullen, 2008; Hu & Bentler, 1999) when the error variance of two items were allowed to correlate. The factor loadings ranged from 0.52 to 0.88. Two statements reflecting high

teacher expectations (e.g., Latino students can close achievement gaps if teachers provide them with rigorous instruction) showed an internal consistency of $\alpha = 0.84$. Confirmatory factor analysis was not conducted due to there only being two items.

Teacher behaviors - Cultural content integration and Spanish language. The teacher behaviors questionnaire was designed to assess the degree to which teachers self-report incorporating ABPs (i.e., cultural content integration and Spanish language) into their daily instruction. The measure was a modified version of the questionnaires developed by experts in ABPs for the National Indian Education Study (NIES), the only large-scale, nationally-representative study that has collected information about the degree to which teachers incorporate culture into the educational experiences of Native American students (López et al., 2013). Teachers were asked to report the extent to which they incorporated students’ culture into instruction (1 = never, 5 = every day or almost every day) with five statements reflecting CCI (e.g., to what extent do you integrate lessons and materials about current issues affecting Latino people and communities into your curriculum?). This scale had an internal consistency of $\alpha = 0.95$ and the items showed acceptable fit in a confirmatory factor analysis, $\chi^2 = 42.35$, $df = 4$, $p < .001$, CFI = 0.98, TLI = 0.96, SRMR = 0.02, RMSEA = 0.12 [90% CI 0.09, 0.15] (Hooper et al., 2008; Hu & Bentler, 1999) when the error variance of two items were allowed to correlate. The factor loadings ranged from 0.80 to 0.95. There were also three statements reflecting the extent to which teachers incorporated Spanish into their instruction (e.g., to what extent do you use Spanish when you teach any core subject?). These items indicated an internal consistency of $\alpha = 0.82$. In a confirmatory factor analysis, fit indices could not be produced as a three-item latent construct is only just-identified. However, the three items loaded onto the latent factor at 0.81, 0.87, and 0.96.

Qualitative Interviews. Trained research assistants conducted 60-min semi-structured interviews with each teacher participant. The interview questions were developed before the quantitative data collection and analysis, and thus were part of the original design. The questions were derived from the Pohan and Aguilar’s (2001) measure on teachers’ beliefs and behaviors regarding historically marginalized students. The interview protocol was designed to allow teachers to freely describe their perceptions about their students. Teachers were asked about what they perceived in terms of their roles in supporting students’ success, as well as the obstacles they and their students faced. The interviewers were trained to use the protocol in a flexible manner, changing the sequence and presentation of questions to allow participants to tell their stories and also to allow the interviewer to follow up on themes and responses of particular interest (Kvale, 1996). Thus, the interviews were intended to corroborate the quantitative survey measure (Pohan & Aguilar, 2001) through a semi-structured approach.

3.3. Data analysis strategy

Quantitative Analysis. Bivariate correlations were initially run to establish relationships among the key variables examined in this study (see Table 1). Given the nested structure of our data (i.e., students

Table 1
Bivariate correlations and descriptive statistics.

	M(SD)	Min/Max	1	2	3	4	5	6
1. Teacher expectancies	4.16(0.92)	2.00/5.00	–	0.15**	0.05	-0.12**	-0.04	0.10*
2. Teacher critical awareness	4.31(0.64)	2.50/4.78		–	0.10*	0.03	-0.03	-0.11*
3. Cultural content integration	3.18(0.90)	1.20/4.80			–	0.61**	0.12**	0.12**
4. Spanish language	3.90(0.77)	2.33/5.00				–	0.00	0.20**
5. Fall math achievement	50.12(19.31)	0.06/118.18					–	0.64**
6. Spring math achievement	50.02(19.51)	-16.16/90.16						–

* p < .05.
** p < .01.

within classrooms), multi-level path analysis using Mplus 7.1 (Muthén & Muthén, 1998–2012) was used to analyze the quantitative data for our research questions. In addressing our first research question, teacher expectations and critical awareness were modeled as classroom-level exogenous variables. CCI and use of Spanish language were also modeled at the classroom level and as serial mediators in the path model. A serial multiple mediation model has two or more mediators modeled consecutive to one another. In our data, we modeled the first mediator, CCI, to predict the second mediator, use of Spanish language in instruction. Last, year-end standardized mathematics achievement was the dependent outcome at the student level. A parallel assessment of mathematics achievement assessed at the beginning of the year was used as a control for year-end mathematics achievement, also measured at the student level. Non-significant pathways were pruned to arrive at final models; in particular, we hoped to find the direct pathways between the independent variables (i.e., teacher expectations & critical awareness) and the dependent outcome (i.e., year-end math achievement) would be non-significant, as this would be an indicator of full mediation through the proposed mediators assuming the indirect effects were statistically significant. Ninety-five percent confidence intervals were reported for indirect effects.

To address the second research question, hypothesizing moderated mediation, we started with the serial multiple mediation model described directly above. To model the indirect effect of the mediators as conditional on critical awareness, we mean-centered the two independent variables (i.e., teacher expectations and critical awareness), multiplied them, and added the interaction term ‘expectations’ by ‘critical awareness’ to predict CCI, controlling for both independent variables. A significant interaction effect here on CCI would be the first sign of evidence for moderated mediation. The second sign would be whether the indirect effect was moderated by critical awareness, versus only on the relation between the independent variable (i.e., teacher expectations) and the first mediator (i.e., cultural content integration). Thus, we report the index of moderated mediation and graph the slope of the indirect effect as based on the moderator, critical awareness. We chose not to employ the random coefficient prediction method (RCP; Preacher, Zhang, & Zyphur, 2016), since both our independent and mediation variables were modeled at the classroom level.

Qualitative Analysis. A constant comparative process was used to analyze the teacher interviews. The constant comparative method allows for consideration of pre-existing evidence (i.e., the quantitative results in this study) to generate or plausibly suggest – but not test – the categories, conditions, consequences, or processes of a new theory (Glaser, 1965). This method involves taking one piece of data (e.g., one incident, one statement, one theme) and comparing it with all others that may be similar or different in order to understand the relations between various pieces of data. This process simultaneously considers the ideas and practices of the participants along with focal concepts of the researcher to allow for both descriptive and explanatory categories (Lincoln & Guba, 1985), as well as the potential for inter-subjectivity (Shannon-Baker, 2016).

The teacher interviews were audio-taped and transcribed verbatim. Once transcribed, the interview texts were read multiple times to get an overall understanding of the teachers’ experiences and perspectives. The central concepts of the quantitative data (i.e., teacher expectations, critical awareness, CCI, and use of Spanish language) were used to code the interview data. First, open coding was used to transform the data into manageable units by organizing the data from each interview into the categories and concepts mentioned just above, as well as new categories that surfaced from the data. Based on open coding, a summary of each interview was developed through consensus of the codes and instances. Second, through axial coding, the codes were grouped to reflect larger thematic and interpretive codes, which allowed for a comparison of codes and themes across the interviewees (Strauss & Corbin, 1998). Next, in selective coding, instances of cultural content integration were prioritized as the core category and compared across

all its instances. When comparisons of instances were made within one interview, similarities, differences, extensions, and consistency were assessed. We then grouped the interviewees based on their initial summaries in the open coding stage and compared instances of cultural content integration, as well as other prominent codes, first with the summaries that were similar to one another and then across those summaries that were less similar (Boeije, 2002). While these teacher interviews were purposively sampled, based on high expectations and critical awareness quantitative scores, theoretical sampling was not employed during the three coding stages.

4. Results

4.1. Quantitative survey results

Initial bivariate correlations between the study variables were statistically significant in the expected directions (see Table 1). However, it is important to note teacher expectations was not significantly related to CCI ($r = 0.05$) and was negatively related to Spanish language use ($r = -0.12$). To address our first research question, a multi-level path analysis was used to model mediation. The independent variables were teacher expectations and critical awareness. CCI was the proposed single mediator. Last, student year-end mathematics achievement was the dependent outcome at the student level, with baseline mathematics achievement as a control. Two models were run: the first was just identified with all direct and indirect pathways modeled, and the second pruned the non-significant pathways from the first model in order to attain fit statistics.

In the second and final model addressing the first research question (see Fig. 3, mediation model 1a), teacher expectations did not predict CCI but were a direct predictor of year-end math achievement. Teacher critical awareness did not predict year-end math achievement but predicted CCI ($\beta = 0.39$). However, CCI was not a significant predictor of year-end math achievement, controlling for baseline achievement. Ultimately, this model could not confirm mediation, as the indirect effects for both teacher expectations ($\beta = -0.02$, $p = .50$ [95%CI -0.07 , 0.03]) and critical awareness ($\beta = 0.07$, $p = .33$ [95%CI -0.07 , 0.21]) through CCI on year-end mathematics achievement were not significant. This model fit the data very well, $\chi^2 = 0.80$, $df = 1$, $p = .37$; CFI = 0.99, RMSEA = 0.00, SRMR = 0.00 [student level]; 0.03 [teacher level] (Hooper et al., 2008; Hu & Bentler, 1999).

Next, the second part of this question (see Fig. 3, mediation model 1b) proposed multiple mediation. Teachers’ use of Spanish language was added to this model as a second mediator, consecutive to CCI. Similar to mediation model 1a, teacher expectations did not predict CCI but teacher critical awareness did ($\beta = 0.40$) with CCI predicting use of Spanish language ($\beta = 0.57$) and language predicting year-end mathematics achievement ($\beta = 0.52$), controlling for baseline mathematics achievement. There were no direct effects of critical awareness or CCI on year-end mathematics achievement. The absence of these direct effects and a statistically significant indirect effects between teacher critical awareness and year-end mathematics achievement (see effects for Mediation Model 1b) suggests this relation is mediated through CCI and use of Spanish language consecutively. This model also fit the data very well with a non-significant chi-square, $\chi^2 = 4.02$, $df = 3$, $p = .26$; CFI = 0.99, RMSEA = 0.03, SRMR = 0.00 [student level]; 0.06 [classroom level]. Altogether, these two models (i.e., models 1a & 1b) indicated that teacher CCI alone does not mediate the relation between teacher beliefs and student mathematics outcomes; however, it works through a second mediator, use of Spanish language, to predict student year-end mathematics achievement.

The serial multiple mediation model, described directly above, was confirmed in that CCI and use of Spanish language were significant consecutive mediators in the relation between critical awareness and year-end mathematics achievement. In order to assess moderated mediation in addressing the second research question (RQ2), an

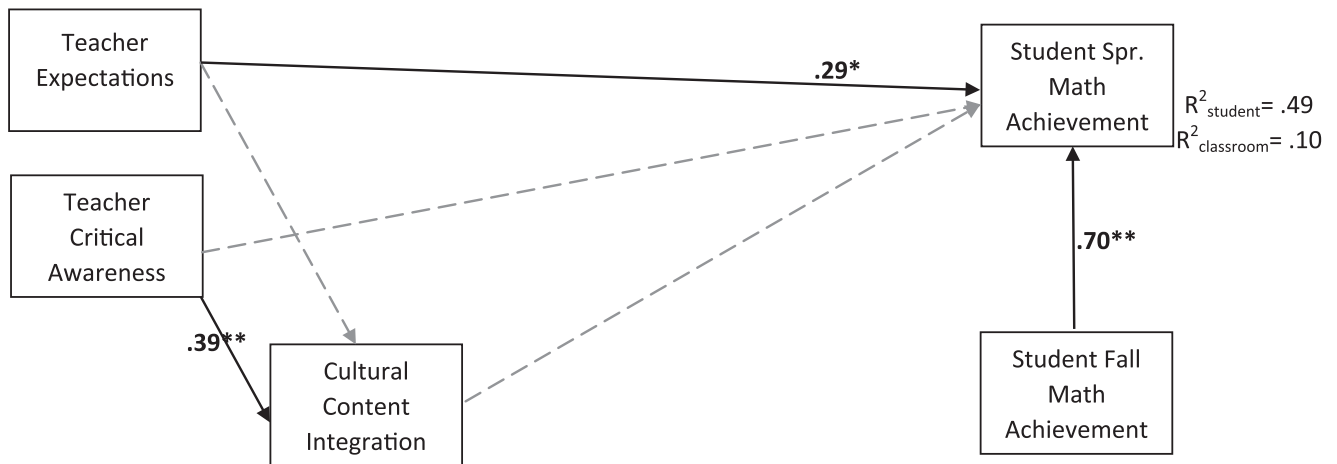

Mediation Model 1a. * $p < .05$. ** $p < .01$. Standardized coefficients ($\chi^2 = 0.80$ $df = 1$, $p = .37$; CFI = .99, RMSEA = .00, SRMR = .00[student level]; .03[classroom level]). Indirect Effect: Teacher Expectations \rightarrow Spring Math Achievement $\beta = -.02$, $p = .50$ [95%CI -.07, .03] Indirect Effect: Critical Awareness \rightarrow Spring Math Achievement $\beta = .07$, $p = .33$ [95%CI -.07, .21]

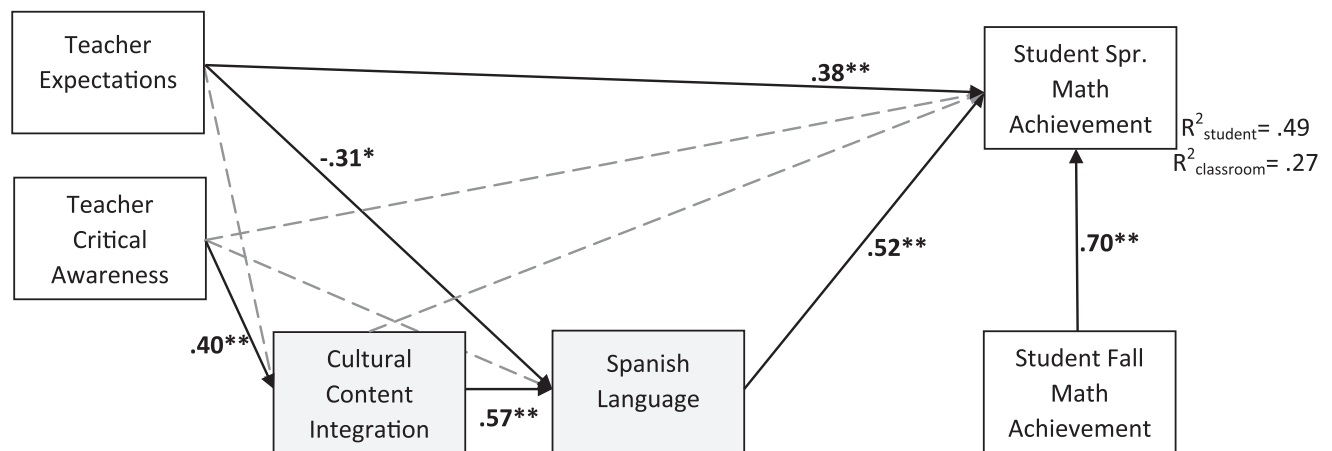

Mediation Model 1b. * $p < .05$. ** $p < .01$. Standardized coefficients ($\chi^2 = 4.02$ $df = 3$, $p = .26$; CFI = .99, RMSEA = .03, SRMR = .00[student level]; .06[classroom level]). Indirect Effect: Teacher Expectations \rightarrow Spring Math Achievement $\beta = -.14$, $p = .09$ [95%CI -.31, .01] Indirect Effect: Critical Awareness \rightarrow Spanish Language $\beta = .25$, $p < .05$ [95%CI .05, .45] Indirect Effect: Cultural Content Integration \rightarrow Spring Math Achievement $\beta = .32$, $p < .05$ [95%CI .03, .61]

Fig. 3. Multi-level path model: research question 1a & 1b.

interaction effect of “expectations” by “critical awareness” on CCI was modeled. This interaction effect significantly predicted CCI in that teachers who had higher expectations of their Latino students but also had high critical awareness of the systemic challenges that Latino children face in education were more likely to integrate cultural content into their instruction (see Table 2). Further, the indirect effect of teacher expectations on student year-end mathematics achievement, mediated through CCI and Spanish language, was positively moderated by teacher critical awareness; although it did not reach statistical significance. Here, the linear function was an intercept of -0.23 with a positive slope of 1.80 [95%CI -0.04 , 4.08]. Fig. 4 illustrates this effect, showing that as critical awareness increased, CCI and use of Spanish

language became a stronger link between teacher expectations and student year-end mathematics achievement. Given the large confidence interval around a strongly positive slope, non-significance in this case was likely due to inadequate power (i.e., only 33 teachers). Overall, these findings showed partial evidence for moderated mediation, with a significant interaction effect but a non-significant (yet positive) indirect effect.

Considering the mediation and moderated mediation results together, high expectations of teachers alone may not be enough to predict teacher enactment of ABPs and subsequent mathematics achievement, rather critical awareness along with high expectations worked together to predict enactment of ABPs and student mathematics

Table 2
Unstandardized regression coefficients (standard errors in parentheses) estimating serial multiple mediation model with moderation effects by critical awareness.

Predictors	Cultural content integration (M_1)		Spanish language (M_2)		Spring math achievement (Y)	
	b(se)	95% CI	b(se)	95% CI	b(se)	95% CI
Fall math ach (student level)	–	–	–	–	0.63** (0.04)	0.56, 0.70
Teacher expectations	–0.08(0.04)	–0.29, 0.13	–	–	3.72** (1.29)	1.20, 6.24
Teacher critical awareness	0.70** (0.08)	0.26, 1.14	–	–	–4.25(2.87)	–9.88, 1.38
Expectations X critical awareness	0.57* (0.09)	0.09, 1.05	–	–	–	–
<i>Mediators</i>						
Cultural content integration	–	–	0.55** (0.11)	0.33, 0.77	–0.99(0.12)	–4.72, 2.74
Spanish language	–	–	–	–	5.84* (2.49)	0.97, 10.72

* $p < .05$.
** $p < .01$.

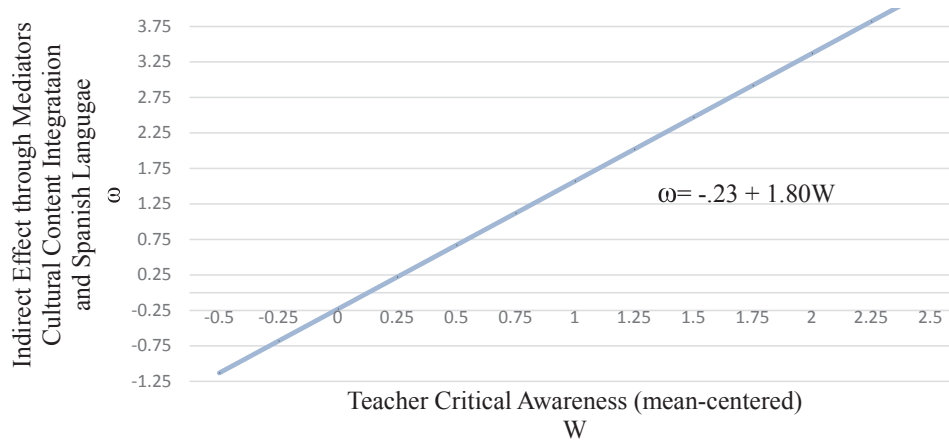

Fig. 4. A visual representation of the linear function relating critical awareness to the indirect effect of teacher expectations on mathematics achievement through cultural content integration and use of Spanish language. Note: 95% confidence interval of the slope was $-0.04, 4.08$.

achievement.

4.2. Qualitative interview results

Transitioning from the survey data, we followed up by conducting interviews with five teachers who showed the highest scores on the survey measures of expectations and critical awareness. We hoped to understand how teachers with equity-based beliefs perceived the value of CCI and using Spanish language in their classroom as well as the nuances therein.

Teacher expectations, critical awareness, CCI, and use of Spanish language were a priori but also predominant codes frequently represented in the interview data. More emergent and inconsistently discussed codes were assessment, education policy and curriculum, building community and culture, knowing your students, parental involvement, and behavior management. Through the constant comparison process, these codes showed some internal nuances but also formed connections with one another in two important ways. The most robust theme to surface from the data was: (1) teachers' ABPs for *socio-engagement* versus *academic* goals. A second theme embedded within the first overarching theme was: (1a) critical awareness and ABPs for academic goals.

(1) Teachers' ABPs for socio-engagement versus academic goals. In the interviews, nearly all the teachers discussed the importance of CCI and use of Spanish language in their instruction, which was expected given the high equity-based beliefs in their quantitative scores. However, despite the overall support for CCI and Spanish, there were also important distinctions among how these teachers discussed the value of ABPs. Some teachers tended to discuss CCI and Spanish as a way to promote cultural pluralism, cultural pride, or to capture student interest. Conversely, other teachers were more likely to discuss CCI and Spanish as opportunities for students to make conceptual connections and enhance learning. Thus, some teachers focused on ABP for *socio-*

engagement goals, whereas others saw the potential for *academic goals*. As an example of the former, one teacher discussed CCI as a mechanism for students to learn about each other's cultures and create classroom community.

Ms. Ballesteros: Um, I think like for any culture, I think that it's important that they hear about especially their own culture, you know and others, we read a lot about different cultures as far as Caucasian, Anglos, different things, Native Americans. But I think it's important that they [Latino students] also learn about their culture. And what they can do. We do Dia de los Muertos and we talk about that. We do a whole thematic unit on that... they talk about their family, their history, their traditions and customs in the beginning of the year. Not just what we like to do but who are we. Who are we and why are we important. Just everyone in here is important and why... So I think it does help building that community. (Latina, 4th grade, teaching 16 years)

This text exemplifies a teacher who is an ardent believer in the importance of CCI; however, her overall goal in this is to build community and promote equity and awareness of the cultures represented in the classroom. Although these are worthy goals for any teacher, they seem to end there, and ABP for academic goals are hardly discussed, even when later probed by the interviewer. This teacher takes a pluralistic perspective on CCI, saying it's important for *any* culture, before coming back to Latino students and talking about the activities around family, history, and traditions. In this text, CCI is noted, but the use of Spanish language and connections between CCI, Spanish, and academic learning is unclear or non-existent. A second teacher, Mrs. Collantes (Latina, 3rd grade, teaching 29 years), showed a similar pattern as just described, yet discussed the importance of Spanish language more explicitly.

Alternatively, three other teachers were more likely to talk about

their CCI and use of Spanish language from a place of inclusion of their students' ideas and strengths. Further, they were more likely to talk about the assets students bring from home (i.e., funds of knowledge) in an academic sense and the importance of CCI and Spanish language for academic learning, versus only social and engagement goals. For example, a mathematics teacher said,

Ms. Orozco: Tapping on my students' funds of knowledge should increase their learning. Those lessons for which I had incorporated elements of my student culture and language have resulted in high-level student engagement and learning. (Latina, 5th grade, teaching 14 years)

As a deeper illustration, Ms. Gomar (Latina, teaching science 13 years) also illustrated her active investment in student knowledge and contributions to the content. She values the importance of allowing students the space to bring their own knowledge and tell their own stories in the classroom, as it relates to academic content and learning.

Ms. Gomar: Using a lot of visuals, using video, using hands on activities, telling personal stories, encouraging them to tell personal stories. Uh, in my particular field of science, the students tend to get a little more curious about tangential topics and whereas we're typically taught not to go off on tangents, I actually like to allow it as long as it has some sort of relationship, because it's feeding the students' interest, and it's, you know, representing their own curiosities..... when we get to topics like ecology, you know, there's a lot of similarity between the, uh, environment around us and that of Mexico, so there's a lot of, um, you know, uh, there's a lot of connectivity there.

Building upon this statement, this teacher, who discussed a lack of comfort speaking the students' language (i.e., Spanish), does not allow that to serve as a deterrent to her using it as an effective tool in the classroom. In fact, she allows her weaknesses in language to be an area where students can assert their strengths, even to the point of correcting and leading the teacher. This enhances the autonomy of the students and conveys an authentic value for their cultural strengths by way of their language. It also illustrates that authority and opportunities for learning are not one-directional but bi-directional and that critique can be healthy and can go both ways between the teacher and students.

Ms. Gomar: Uh, I don't speak Spanish very well. The little bit of Spanish I do speak I picked up here. I find one of the things that I can do in that light that students respond to is I could have them teach me, which they get into and then let them make fun of me when I mispronounce things. They love that! Um, but it-it definitely has value.

As another example, Ms. Ramirez is able to understand the connections between CCI, Spanish language, and opportunities for academic learning, not just cultural pride.

Ms. Ramirez: Um, cultural practices, yes, you want kids... first off, you want them to be comfortable with you. You want them to be comfortable in the classroom, but if you're giving value to their cultural practices, you're giving value to them. So then they feel like-they feel at home or at least comfortable in school, even if your teacher's a *guera* [A colloquial Spanish term for white female]. You know and the same thing with family/community... The more I can connect what I'm teaching to what they already know, the better chance I have of them actually learning it. I mean all learning is connections. It's learning what you know, connecting what's new to something you already know so that you can kinda remember or kinda understand it and build on it. And if you use what they already come with, then those connections are quicker and easier and,

it's easier for the kid. So I think that the kids who are really bilingual, it increases their academic success. With two languages you're doubling the amount of ways to connect. When you teach them evaporation and evaporation if they've heard it in Spanish, you know, it doubles your chances again. (Latina, 3rd grade, teaching 21 years)

She went on further to state how integral Spanish instruction is to early academic success, mathematics skills, and English language development.

I mean trying to help them with their language skills um and their math skills. I'm really a concept teacher, and I try to teach concepts and have them build on their concepts. But I also don't want them to not be able to practice basic algorithms and skills. So I try to do both... I really don't like the SEI program and how they do it all in English. Having said that, sometimes they're transitioned out of it too soon. Um, some of our kids because of the way the 203 law is written and they go to kinder[garten], and if they don't speak English, they're in the English only. So, a lot of those kids really don't have a very good base in Spanish, and then they're supposed to build a second language on it, and they don't have it.

Here, Ms. Ramirez is referring to Proposition 203 that replaced bilingual education (i.e., instruction that uses students' primary non-English language as a scaffold as they acquire English via subject matter) with Structured English Immersion (SEI). The law states that students "shall be taught English by being taught in English... during a temporary transition period not normally intended to exceed one year" (A.R. S. § 15–752). In her comment, she expressed frustration that has been documented at length regarding the lack of research undergirding SEI (Combs, Evans, Fletcher, Parra, & Jiménez, 2005). Moreover, she alluded to the critical issue that SEI denies students access to the requisite knowledge that can promote learning in both linguistic and basic mathematics concepts. Within the context of this political environment, another teacher remarked on the decline of Spanish language and instruction in the primary grades in her school.

Mrs. Collantes: Like every year I see a little bit less Spanish than in previous years.

Before, most of students in third grade were already bilingual. Reading and writing and it seems like every year is less and less and less Spanish. And you have to kinda like force them to speak Spanish now... I really, really emphasize Spanish, and it's a struggle... Cuz they haven't had the foundation-that foundation of kinder[garten] and first, which is 100 percent Spanish. So we get-we get 'em in third grade and they're completely low already in their first language, you know, it's hard. (3rd grade, teaching 29 years)

(1a) Critical awareness and ABPs for academic goals. In considering the differences in teachers' understanding and value of CCI, we re-visited the interview texts again to investigate other patterns that aligned with these differences. We found that teachers who discussed the power of CCI and Spanish language for academic learning also tended to have elements of their interview that reflected acute awareness of cultural marginalization, bias in schools and testing, and critical awareness about the effects of poverty on Latino youth. Essentially, they all naturally discussed the sociopolitical forces that can act as barriers to success for Latino children in schools. These seemed to surface in the interview text naturally, although they were not always mentioned in combination with their articulation of the importance of CCI or Spanish language. Despite high critical awareness in the survey as criteria for all five teachers selected for follow-up interviews, some teachers still lacked a certain level of density and detail in their discussion of critical awareness in their interviews. At times, evidence of critical awareness was absent altogether. Our analysis showed that it

was these teachers who were also more likely to discuss their ABP behaviors as important for socio-engagement goals without specifying connections to academic learning.

Ms. Gomar and Ms. Ramirez represent two clear examples of how instructors value cultural content awareness and use Spanish language for academic learning as well as for community building. However, it's important to reinforce that these two teachers also shared similarities in how they discussed their critical awareness beliefs as well as cultural biases that perpetuate inequity. For example Ms. Gomar says:

Um, I think that they're [standardized tests] used to measure teachers, and I think if we are really going to concern ourselves with learning, we should be focusing on the students. I think they create added stress. I think often times they're culturally bias. For example, I remember when I was in Florida, we had the same sort of thing there they called in an FCAT [Florida Comprehensive Assessment Test]. There was one question on one of the tests where the student was supposed to liken the framework of a house to a body system and it showed a wood frame and the students had never seen a wood frame, because everything down there was built with cinderblocks because of hurricanes. So, I mean, it wasn't even, when I say culturally bias, it wasn't even like a particular ethnicity, it was bias to the actual, yeah, population of the state.

Similarly, Ms. Ramirez mentions:

And, so I think that educational equity is really difficult because it's very hard to make any kind of equitable test. I think it's very difficult because there are kids that come at it in a different perspective. So that's not a racially biased equity but those kind of, it's really difficult to come up with an equitable test. So, if assessment has a role in efforts to achieve educational equity, if it's a multiple guess test, chances are it's not gonna happen.

Through these testimonies, the qualitative interview data reveals consistencies as well as extensions to the quantitative survey trends. Although possessing critical awareness is important for asset-based pedagogies (i.e., CCI & use of Spanish) for our general sample of teachers, this interview data also reveals that even high critically aware teachers can have differing goals in understanding the importance of ABP and that critical awareness helps guide that understanding. The current data suggested some teachers perceived these practices as important for social and engagement goals, and those who did were less likely to invoke critical awareness in their interviews. However, other teachers agreed with the importance of socio-engagement goals but also saw the potential of these practices for academic learning. These teachers were more likely to espouse consistent details that reflected their critical awareness.

5. Discussion

In this study, we employed an explanatory sequential mixed methods design to understand teachers' use of asset-based pedagogies with elementary Latino children, as well as the antecedents and outcomes of these instructional practices and the nuances of how teachers understand and value these practices. First mediation and moderation techniques were utilized to assess the relation between teacher beliefs, teacher pedagogy, and Latino students' mathematics achievement. Following this, we made use of semi-structured interviews to probe teachers' perceptions of the value of ABPs.

The quantitative data revealed that among the two teacher beliefs explored in this study (i.e., expectations and critical awareness), only critical awareness was a significant predictor of CCI. In turn, CCI also predicted use of Spanish language, which predicted students' year-end mathematics achievement; controlling for baseline mathematics achievement. There were no predictive effects of critical awareness nor

CCI on year-end mathematics achievement, signaling a full mediation pathway starting with critical awareness to CCI, CCI to Spanish language, and finally, Spanish language to mathematics achievement. This finding implies that honoring heritage language may be the quintessential mouth piece (pun intended) of CCI, and that integrating students' culture into instruction through honoring their language is meaningful for student learning, even in mathematics where the connections between bilingualism and learning may be less clear. Although this has been previously theorized (Darder, 2012; González, 2001), there has been little empirical testing to support this idea. Thus, the current study addresses an important gap in the ABP and multicultural education literature.

Interestingly, while teacher expectations directly and positively predicted year-end mathematics achievement, it failed to predict teachers' ABPs. This finding is well positioned among a few existing studies suggesting that teachers' expectations are confounded with students' cultural background, and therefore reflect bias (McKown & Weinstein, 2002; Tenenbaum & Ruck, 2007). Further, this reveals that simply having high expectations for historically marginalized youth is not enough for teacher enactment of asset-based pedagogies. In fact, teacher expectations alone were a negative predictor of Spanish language use. This may suggest that teachers with high expectations that are rooted in deficit, culturally-biased thinking subconsciously expect Latino students to rise to Anglo-centric learning values and customs, thus prioritizing English instruction and subjugating students' heritage language (Spanish). This highlights the importance of critical awareness in combination with high expectations, which we examined next.

Indeed, the moderation analyses revealed that critical awareness beliefs interacted with teacher expectations for a significant effect on CCI. Further, the indirect effect of teacher expectations on student performance, through ABPs, was positively moderated by critical awareness, although was not statistically significant. Future replications of this work should include a larger teacher sample size to assess the validity of this effect. Consistent with the interaction effect in the survey data, teachers' articulation of their use and value of CCI and Spanish language in their interviews seemed to be related to critical awareness beliefs as well. While we found that many teachers discussed the importance of CCI and Spanish language, teachers with under-specified critical awareness beliefs were more likely to discuss these practices as a tool to promote cultural pride, capture student interest/engagement, and build classroom community. These are not poor goals by any means; however, teachers with more detailed articulation of their critical awareness beliefs were more likely to talk about CCI and Spanish language from a place of inclusion of students' ideas and strengths, and utilizing students' funds of knowledge to make connections to the content and support academic learning. These teachers also discussed CCI and Spanish for facilitating student interest and building community; however, they were more explicit about this as a means to an end for academic learning, not only for fostering community and engagement.

Altogether our findings emphasize that honoring heritage language in instruction is a fundamental aspect of utilizing students' assets not only to promote social outcomes, but for academic learning as well. Previous research (Clarkson, 2007) as well as the teacher interviews indicate that language can be leveraged to give students more linguistic and conceptual resources for making connections that foster learning. In addition, through these data, we understand that high expectations alone may not be enough to predict teacher enactment of ABPs, rather critical awareness along with high expectations work together to predict enactment of culturally responsive teaching and growth in student mathematics learning specifically.

Using an explanatory sequential mixed methods design was particularly powerful for uncovering our findings, as well as cross-validating the integrity of those findings. We used contiguous integration at the reporting level, first reporting the quantitative results, which were given priority in this study, followed by the qualitative results (Fetters,

Curry, & Creswell, 2013). The quantitative data provided support for the pathway by which teacher beliefs predicted ABPs and student mathematics achievement; however, it was unable to explain how teachers made sense of this process and how they enacted ABPs in their classrooms. The qualitative interviews not only provided evidence of confirmation of the quantitative trends, highlighting the importance of critical awareness for ABPs, but also showed evidence of expansion (Fetters et al., 2013) of the quantitative data, revealing that teachers can perceive ABPs not only for socio-engagement value, but also for academic learning. This highlights the promise and potential validation power of mixed methods research in studying complex social and psychological phenomena.

5.1. Extended implications, limitations, & future directions

Clearly, critical awareness contributes to what teachers really believe and understand about their students, their students’ culture, and their own pedagogical responsibilities. While teachers can potentially adopt a deficiency lens of students based on their cultural background, a critical awareness allows them to evaluate the systemic and hegemonic forces that may foster biased perceptions of the learning abilities and performance of children of color; thus recognizing the need for pedagogical approaches that affirm students’ culture and potential. In addition, this work reinforces an important caveat in the seminal work of Gloria Ladson-Billings (1995b), who emphasized the importance of teachers holding high expectations for marginalized youth. While that claim is in no way erroneous, the current data and Ladson-Billings (1995b) suggest those beliefs may be moot for predicting culturally responsiveness if not paired with a critical awareness to the unique challenges that socially marginalized children face in education and beyond, as well as the socio-historical influences on achievement disparities. This point is important to understand because many scholars and practitioners have appropriated Ladson-Billings (1995b) comments on high expectations, but have neglected the importance of pairing it with critical awareness. Altogether, teachers need continued training and reinforcement on addressing implicit and explicit biases against socially marginalized children, as well as support for being able to see their children’s culture as an asset for their learning (Dee & Penner, 2016).

Our intention in this research was not to promote the value of Spanish instruction over English, nor was it to pit the instruction of either language against each other. Rather, we hoped to illustrate that using students’ heritage language can be an asset to learning and performance in English-based classrooms. However, prior research also reveals an important caveat: the primary language must meet a minimum level of competence/proficiency, and it must have social value as a language of thought and expression (Baker, 1996; Clarkson, 1992, 2007; Secada, 1992). This latter point lends itself to the crux of this study precisely; that is, teachers must honor student language as a valid currency for social value, thought, and expression, versus perceiving it as a crutch needed for remediation. Further, while these results likely cannot be generalized outside of the immediate context, this research might have implications for other ethnic minority populations whose language and culture have been subjugated to hegemonic White-American norms. While the utility of African American Vernacular

English (AAVE) as an instructional tool in American schools has been ardently debated, there is at least some evidence to suggest that using the language of hip-hop music can support learning and performance in science among urban youth for whom hip-hop culture is a valid form of expression and communication (Emdin, 2008; Emdin & Lee, 2012).

Despite the contributions of this study, it also possesses limitations as well as leaves some lingering questions unaddressed. First, multiple variables in the quantitative data relied on survey instruments, of which social desirability as well as coefficient inflation are important to consider. Second, teacher pedagogical behaviors were also self-reported, which leaves this mediating variable up to teachers’ subjective perception of their frequency of engaging in these behaviors. Future work replicating this study should utilize objective observation of teachers’ ABPs, although to our knowledge such a structured observational measure does not currently exist. Last, this research leaves unanswered the very real questions of *how*, *when*, and *where* can teachers best integrate heritage language into their instruction. Native speakers of the language may have a more intuitive sense of how to facilitate this; however, teachers who are new to students’ heritage language will likely lack the confidence and knowledge on how to effectively and consistently use this asset-based tool. Future research should investigate how effective teachers use students’ culture and language to promote classroom community as well as academic learning. One hint may lay in the opening quote of this article, with one teacher with limited Spanish proficiency, using this “limitation” as an opportunity to allow the students to teach her and assume a role of expertise in the classroom.

Given the limitations and need for continued research, mixed methods triangulation of data in this body of work revealed the vital relationship with critical awareness that teacher expectations requires to reach better student outcomes for historically-marginalized students, specifically Mexican-descent Latino children. It is clear that teachers who described in greater detail their own conceptualization of critical awareness incorporated CCI and Spanish language as a means not only of creating an inclusive, tolerant, and comfortable communal environment in the classroom, but as a significant tool for furthering learning by way of making broader and deeper connections between student prior knowledge and academic content. As discussed, our work uncovers the benefit and need for coursework for teachers around critical awareness, which could be the key to creating classrooms and systems that foster greater success and scholastic outcomes for historically-marginalized students.

Acknowledgement

The authors thank Charlene Bruce, Benjamin Caldera, Angela Champion, Mitzzy Ocegueda González, Isabel Kelsey, Veronica Romo, Ruby Vega, and Marylyn Valencia for their assistance; Augustine Romero and H. T. Sanchez for their support of this project; and the administrators, teachers, and students of the participating school district for their participation and support. The research reflected in this paper was supported in part by the National Academy of Education’s Spencer postdoctoral fellowship program, awarded to the second author.

Appendix A. Appendix

Survey items	Interview questions
Critical awareness	
1 Tests, particularly standardized tests, have frequently been used as a basis for segregating Latino students.	1 Can you tell me about the students in your class this year? (<i>Whatever is most relevant or salient to teacher is fine.</i>)
2 The traditional classroom has been set up to support the dominant (White) culture.	2 Are your students this year typical of those you have had in the past?

- 3 Historically, education has been mono-cultural, reflecting only one reality and has been biased toward the dominant (White) group.
- 4 Students living in ethnically isolated neighborhoods can benefit socially from participating in ethnically integrated classrooms.
- 5 Students from lower socioeconomic backgrounds typically have fewer educational opportunities than their middle-class peers.
- 3 In your experience, which students are particularly challenging to work with? What is your role in helping them to succeed? (*Try to get them to give specific examples of situations and their practices to address them.*)
- 4 What are some of the specific challenges that Latino students face in academic settings? What is your role in supporting these students?
- 5 What do you believe would increase the achievement of your Latino students?
- 6 What have you found to be the greatest difficulty for increasing the achievement of your Latino students?

Heritage language

- 12 To what extent do you speak Spanish
- 13 To what extent do you use Spanish when you teach any core subject (reading, mathematics, science, and social studies)?
- 14 To what extent do you allow students to use Spanish when you teach any core subject (reading, mathematics, science, and social studies)
- 7 Is it important to incorporate Latino students’ native language, cultural practices, and family/community in your classroom instruction? Why or why not?
- 8 (*If it is important*) How do you think this type of instruction impacts students’ academic success? Their social development? How do you achieve this in your classroom? Can you give me a specific example? How do you know when you have done this successfully?
- 1 Can you tell me about the students in your class this year? (*Whatever is most relevant or salient to teacher is fine.*)
- 2 Are your students this year typical of those you have had in the past?
- 3 In your experience, which students are particularly challenging to work with? What is your role in helping them to succeed? (*Try to get them to give specific examples of situations and their practices to address them.*)
- 4 What are some of the specific challenges that Latino students face in academic settings? What is your role in supporting these students?
- 5 What do you believe would increase the achievement of your Latino students?
- 6 What have you found to be the greatest difficulty for increasing the achievement of your Latino students?

Expectations

- 15 Latino students can close achievement gaps if teachers provide them with rigorous instruction.
- 16 Latino students can be successful academically if they are exposed to a rigorous curriculum.
- 1 Can you tell me about the students in your class this year? (*Whatever is most relevant or salient to teacher is fine.*)
- 2 Are your students this year typical of those you have had in the past?
- 3 In your experience, which students are particularly challenging to work with? What is your role in helping them to succeed? (*Try to get them to give specific examples of situations and their practices to address them.*)
- 4 What are some of the specific challenges that Latino students face in academic settings? What is your role in supporting these students?
- 5 What do you believe would increase the achievement of your Latino students?
- 6 What have you found to be the greatest difficulty for increasing the achievement of your Latino students?

Cultural content integration

- 18 To what extent do you integrate lessons and materials about Latino culture and history into your curriculum
- 19 To what extent do you integrate lessons and materials about current issues affecting Latino people and communities into your curriculum?
- 20 To what extent do you participate in activities that integrate the subject with Latino themes?
- 21 To what extent do you incorporate traditional Latino topics into instruction
- 22 To what extent do you read about or discuss current issues of concern to the Latino community
- 3 In your experience, which students are particularly challenging to work with? What is your role in helping them to succeed? (*Try to get them to give specific examples of situations and their practices to address them.*)
- 4 What are some of the specific challenges that Latino students face in academic settings? What is your role in supporting these students?
- 5 What do you believe would increase the achievement of your Latino students?

Note: Interview items were constructed to be “open,” however, some questions are relevant to more than one category. We have numbered the interview questions such that each unique question has a unique number, which is then repeated in the appropriate categories.

References

- Apple, M. W. (2004). *Ideology and curriculum* (3rd ed.). Boston, MA: Routledge.
- Baker, C. (1996). *Foundations of bilingual education and bilingualism*. Clevedon, United Kingdom: Multilingual Matters.
- Banks, J. A. (1993). Multicultural education: Historical development, dimensions, and practice. *Review of Research in Education*, 19, 3–49. <http://dx.doi.org/10.3102/0091732X019001003>.
- Bergan, J. R., Burnham, C. G., Bergan, J. R., & Bergan, K. C. (2011). *Benchmark assessment development in the Galileo K-12 online educational management system*. Retrieved at <http://www.ati-online.com/pdfs/researchK12/K12TechManual.pdf>.
- Boeije, H. R. (2002). A purposeful approach to the constant comparative method in the analysis of qualitative interviews. *Quality and Quantity*, 36, 391–409. <http://dx.doi.org/10.1023/A:1020909529486>.
- Bowles, S., & Gintis, H. (1976). *Schooling in capitalist America: Educational reform and the contradictions of economic life*. New York, NY: Basic Books.
- Brophy, J., & Good, T. L. (1984). *Occasional paper no. 73: Teacher behavior and student achievement*. Retrieved from <https://education.msu.edu/irt/PDFs/OccasionalPapers/op073.pdf>.
- Brophy, J. E., & Good, T. L. (1970). Teachers' communication of differential expectations for children's classroom performance: Some behavioral data. *Journal of Educational Psychology*, 61, 365–374. <http://dx.doi.org/10.1037/h0029908>.
- Cabrera, N. L., Milem, J. F., Jaquette, O., & Marx, R. W. (2014). Missing the (student achievement) forest for all the (political) trees: Empiricism and the Mexican American studies controversy in Tucson. *American Educational Research Journal*, 51, 1084–1118. <http://dx.doi.org/10.3102/0002831214553705>.
- Clarkson, P. C. (1992). Language and mathematics: A comparison of bilingual and monolingual students of mathematics. *Educational Studies in Mathematics*, 23, 417–429. <http://dx.doi.org/10.1007/BF00302443>.
- Clarkson, P. C. (2007). Australian Vietnamese students learning mathematics: High ability bilinguals and their use of their languages. *Educational Studies in Mathematics*, 64, 191–215. <http://dx.doi.org/10.1007/s10649-006-4696-5>.
- Combs, M. C., Evans, C., Fletcher, T., Parra, E., & Jiménez, A. (2005). Bilingualism for the children: Implementing a dual-language program in an English-only state. *Educational Policy*, 19, 701–728. <http://dx.doi.org/10.1177/0895904805278063>.
- Creswell, J. W. (2003). *Research design: Qualitative, quantitative, and mixed method approaches* (2nd ed.). Thousand Oaks, CA: Sage Publications Inc.
- Creswell, J. W. (2005). *Educational research: Planning, conducting, and evaluating quantitative and qualitative approaches to research* (2nd ed.). Upper Saddle River, NJ: Pearson Education.
- Creswell, J. W., Plano Clark, V. L., Gutmann, M. L., & Hanson, W. E. (2003). Advanced mixed methods research designs. In A. Tashakkori, & C. Teddlie (Eds.). *Handbook on mixed methods in the behavioral and social sciences* (pp. 209–240). Thousand Oaks, CA: Sage Publications Inc.
- Darder, A. (2012). *Culture and power in the classroom: Educational foundation for the schooling of bicultural students* (2nd ed.). NY, NY: Routledge.
- Dee, T., & Penner, E. (2016). *The causal effects of cultural relevance: Evidence from an ethnic studies curriculum (NBER Working Paper No. 21865)*. Retrieved from National Bureau of Economic Research website <http://www.nber.org/papers/w21865>.
- Emdin, C. (2008). The three C's for urban science education. *Phi Delta Kappan*, 89, 772–775. <http://dx.doi.org/10.1177/003172170808901018>.
- Emdin, C., & Lee, O. (2012). Hip-hop, the Obama effect, and urban science education. *Teachers College Record*, 114(2), 1–24.
- Fetters, M. D., Curry, L. A., & Creswell, J. W. (2013). Achieving integration in mixed methods designs—Principals and practices. *Health Services Research*, 48, 2134–2156. <http://dx.doi.org/10.1111/1475-6773.12117>.
- Freire, P. (1970). *Pedagogy of the oppressed*. New York, NY: Herder and Herder.
- Gándara, P., & Orfield, G. (2012). Segregating Arizona's English learners: A return to the "Mexican room"? *Teachers College Record*, 114(9), 1–27.
- García, O. (2009). *Bilingual education in the 21st century: A global perspective*. Malden, MA: Wiley-Blackwell.
- Gay, G. (2010). *Culturally responsive teaching: Theory, research, and practice* (2nd ed.). New York, NY: Teachers College Press.
- Glaser, B. (1965). The constant comparative method of qualitative analysis. *Social Problems*, 12, 436–445. <http://dx.doi.org/10.2307/798843>.
- González, N. (2001). *I am my language: Discourses of women and children in the borderlands*. Tucson, AZ: University of Arizona Press.
- González, N., Moll, L., & Amanti, C. (Eds.). (2005). *Funds of knowledge: Theorizing practices in households, communities, and classrooms*. NY, NY: Routledge, Taylor & Francis Group.
- Good, T., & Nichols, S. (2001). Expectancy effects in the classroom: A special focus on improving the reading performance of minority students in first-grade classrooms. *Educational Psychologist*, 36, 113–126. http://dx.doi.org/10.1207/S15326985EP3602_6.
- Gorski, P. C. (2013). *Reaching and teaching students in poverty: Strategies for erasing the opportunity gap*. New York, NY: Teachers College Press.
- Gutiérrez, R. (2002). Beyond Essentialism: The complexity of language in teaching mathematics to Latina/o students. *American Educational Research Journal*, 39, 1047–1088. <http://dx.doi.org/10.3102/000283120390041047>.
- Gutiérrez, K., & Rogoff, B. (2003). Cultural ways of learning: Individual traits or repertoires of practice. *Educational Researcher*, 32(5), 19–25.
- Gutstein, E. (2008). Connecting community, critical, and classical knowledge in teaching mathematics for social justice. In B. Srimaran (Ed.). *International perspectives on social justice in mathematics education* (pp. 153–167). Charlotte, NC: Information Age Publishing.
- Hooper, D., Coughlan, J., & Mullen, M. R. (2008). Structural equation modeling: Guidelines for determining model fit. *Electronic Journal of Business Research Methods*, 6, 53–60.
- Hu, L. T., & Bentler, P. M. (1999). Cutoff criteria for fit indexes in covariance structure analysis: Conventional criteria versus new alternatives. *Structural Equation Modeling*, 6, 1–55. <http://dx.doi.org/10.1080/10705519909540118>.
- Ivankova, N. V., Creswell, J. W., & Stick, S. L. (2006). Using mixed methods sequential explanatory design: From theory to practice. *Field Methods*, 18, 3–20. <http://dx.doi.org/10.1177/1525822X05282260>.
- Jussim, L., Eccles, J., & Madon, S. (1996). Social perception, social stereotypes, and teacher expectations: Accuracy and the quest for the powerful self-fulfilling prophecy. *Advances in Experimental Social Psychology*, 28, 281–388. [http://dx.doi.org/10.1016/S0065-2601\(08\)60240-3](http://dx.doi.org/10.1016/S0065-2601(08)60240-3).
- Jussim, L., & Harber, K. D. (2005). Teacher expectations and self-fulfilling prophecies: Knowns and unknowns, resolved and unresolved controversies. *Personality and Social Psychology Review*, 9, 131–155. http://dx.doi.org/10.1207/s15327957pspr0902_3.
- Kantor, H. (1991). Education, social reform, and the state: ESEA and federal education policy in the 1960s. *American Journal of Education*, 100, 47–83. <http://dx.doi.org/10.1086/444004>.
- Kohl, H. (1991). *I won't learn from you! The role of assent in learning*. Minneapolis, MN: Milkweed Editions.
- Kumar, R., & Hamer, L. (2013). Preservice teachers' attitudes and beliefs toward student diversity and proposed instructional practices: A sequential design study. *Journal of Teacher Education*, 64, 162–177. <http://dx.doi.org/10.1177/0022487112466899>.
- Kvale, S. (1996). *Interviews: An introduction to qualitative research interviewing*. Thousand Oaks, CA: Sage Publications.
- Ladson-Billings, G. (1995a). Toward a theory of culturally relevant pedagogy. *American Educational Research Journal*, 47, 465–491. <http://dx.doi.org/10.3102/00028312032003465>.
- Ladson-Billings, G. (1995b). But that's just good teaching! The case for culturally relevant pedagogy. *Theory Into Practice*, 34, 159–165. <http://dx.doi.org/10.1080/00405849509543675>.
- Ladson-Billings, G. (1999). Preparing teachers for diverse student populations: A critical race theory perspective. *Review of Research in Education*, 24, 211–247. <http://dx.doi.org/10.3102/0091732X024001211>.
- Ladson-Billings, G. (2003). New directions in multicultural education: Complexities, boundaries, and critical race theory. In J. A. Banks (Ed.). *Handbook of research on multicultural education* (pp. 50–65). San Francisco, CA: Jossey-Bass.
- Lincoln, Y. S., & Guba, E. G. (1985). *Naturalistic inquiry*. Newbury Park, CA: Sage Publications Inc.
- López, F. (2016). Teacher reports of culturally responsive teaching and Latino students' reading achievement in Arizona. *Teachers College Record*, 118(5).
- López, F. (2017). Altering the trajectory of the self-fulfilling prophecy: Asset-based pedagogy and classroom dynamics. *Journal of Teacher Education*, 68, 193–212.
- López, F., Heilig, J., & Schram, J. (2013). A story within a story: Cultural responsive schooling and American Indian and Alaska Native achievement in the National Indian Education Study. *American Journal of Education*, 119, 513–538.
- McKown, C. (2013). Social equity theory and racial-ethnic achievement gaps. *Child Development*, 84, 1120–1136. <http://dx.doi.org/10.1111/cdev.12033>.
- McKown, C., & Weinstein, R. S. (2002). Modeling the role of child ethnicity and gender in children's differential responses to teacher expectations. *Journal of Applied Social Psychology*, 32, 159–184. <http://dx.doi.org/10.1111/j.1559-1816.2002.tb01425.x>.
- Merton, R. K. (1948). *The self-fulfilling prophecy*. *The Antioch Review*, 8, 193–210. <http://dx.doi.org/10.2307/4609267>.
- Muthén, L. K., & Muthén, B. O. (1998–2012). *Mplus user's guide* (7th ed.). Los Angeles, CA: Muthén & Muthén.
- National Council of Teachers of Mathematics. (2014). *Principles to actions: Ensuring mathematical success for all*. Reston, VA: Author.
- Pajares, M. F. (1992). Teachers' beliefs and educational research: Cleaning up a messy construct. *Review of Educational Research*, 62, 307–332. <http://dx.doi.org/10.3102/00346543062003307>.
- Pohan, C. A., & Aguilar, T. E. (2001). Measuring educators' beliefs about diversity in personal and professional contexts. *American Educational Research Journal*, 38, 159–182. <http://dx.doi.org/10.3102/00028312038001159>.
- Preacher, K. J., Zhang, Z., & Zyphur, M. J. (2016). Multilevel structural equation models for assessing moderation within and across levels of analysis. *Psychological Methods*, 21, 189–205. <http://dx.doi.org/10.1037/met0000052>.
- Rosenthal, R. (1994). Interpersonal expectancy effects: A 30-year perspective. *Current Directions in Psychological Science*, 3, 176–179. <http://dx.doi.org/10.1111/1467-8721.ep10770698>.
- Rosenthal, R., & Jacobson, L. (1968). Pygmalion in the classroom. *The Urban Review*, 3(1), 16–20. <http://dx.doi.org/10.1007/BF02322211>.
- San Miguel, G., & Valencia, R. R. (1998). From the treaty of Guadalupe Hidalgo to Hopwood: The educational plight and struggle of Mexican Americans in the Southwest. *Harvard Educational Review*, 68, 353–413. <http://dx.doi.org/10.17763/haer.68.3.k01tu242340242u1>.
- Secada, W. G. (1992). Race, ethnicity, social class, language, and achievement in mathematics. In D. A. Grouws (Ed.). *Handbook of research on mathematics teaching and learning: A project of the national council of teachers of mathematics* (pp. 623–660). New York, NY: Macmillan.
- Shannon-Baker, P. (2016). Making paradigms meaningful in mixed methods research. *Journal of Mixed Methods Research*, 10, 319–334. <http://dx.doi.org/10.1177/1558689815575861>.
- Spiegel, A. (2012, September 17). *Teachers' Expectations Can Influence How Students*

- Perform. Retrieved from <http://www.npr.org/sections/health-shots/2012/09/18/161159263/teachers-expectations-can-influence-how-students-perform>.
- Strauss, A., & Corbin, J. (1998). *Basics of qualitative research: Techniques and procedures for developing grounded theory* (2nd ed.). London, United Kingdom: Sage Publications Inc.
- Tate, W. F. (2005). *Access and opportunities to learn are not accidents: Engineering mathematical progress in your school*. Greensboro, NC: SERVE Center at the University of North Carolina at Greensboro.
- Tenenbaum, H. R., & Ruck, M. D. (2007). Are teachers' expectations different for racial minority than for European American students? A meta-analysis. *Journal of Educational Psychology, 99*, 253–273. <http://dx.doi.org/10.1037/0022-0663.99.2.253>.
- Tharp, R. G. (1989). Psychocultural variables and constants: Effects on teaching and learning in schools. *American Psychologist, 44*, 349–359. <http://dx.doi.org/10.1037/0003-066X.44.2.349>.
- Turner, E. E., & Drake, C. (2016). A review of the research on prospective teachers' learning about children's mathematical thinking and cultural funds of knowledge. *Journal of Teacher Education, 67*, 32–46. <http://dx.doi.org/10.1177/0022487115597476>.
- Valenzuela, A. (1999). *Subtractive schooling: U.S.-Mexican youth and the politics of caring*. Albany, NY: SUNY Press.
- Valenzuela, A. (Ed.). (2016). *Growing critically conscious teachers: A social justice curriculum for educators of latino/a youth*. New York, NY: Teachers College Press.
- Zhang, Y. (2014, April). Educational expectations, school experiences and academic achievements: A longitudinal examination. Gansu Survey of Children and Families Papers. Retrieved from: http://repository.upenn.edu/cgi/viewcontent.cgi?article=1021&context=gansu_papers.
- Zirkel, S. (2008). The influence of multicultural education practices on student outcomes and intergroup relations. *Teachers College Record, 110*, 1147–1181.